

READ ALL INSTRUCTIONS COMPLETELY BEFORE PROCEEDING

COMPONENT IDENTIFICATION

ITEMS REQUIRED FOR ASSEMBLY

1. Jacket Stripper (available from Panduit)
2. Diagonal Cutters (not available from Panduit)
3. Fiber optic cable with 0.19" (4.8mm) to 0.31" (7.9mm) dia, round outer jacket and aramid yarn.

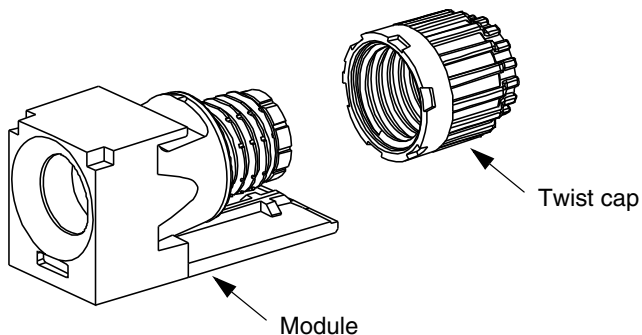

CMCSR**

1.

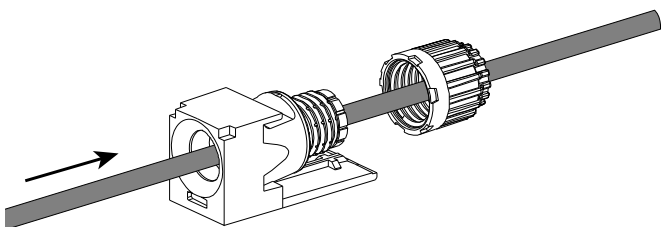

Feed fiber through hole in front of module and twist cap.

2.

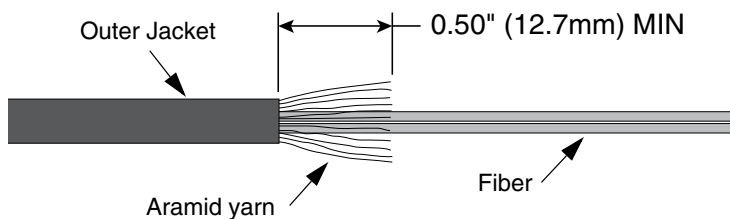

Strip outer jacket to provide desired fiber length behind module. Do not damage or cut the inner fiber jackets or aramid yarn. Cut the aramid yarn a minimum length of 0.50" (12.7mm).

3.

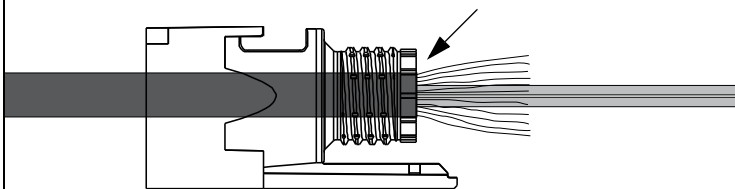

Align the end of the cable outer jacket to the end of the module threads. **NOTE: THIS IS A CRITICAL STEP TO ENSURE THE CABLE IS SECURED TIGHTLY (WITH NO SLACK) TO THE MODULE.**

4.

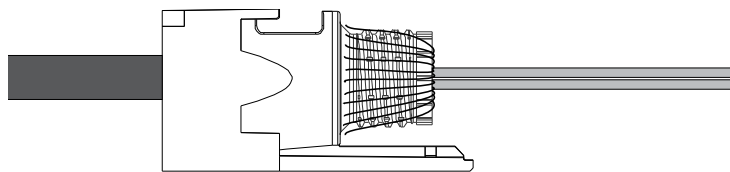

Flare aramid yarn evenly around the threads of the module.

Product Operating Temperature: 0° - 75°C (32° - 167°F)

** Denotes color

5.

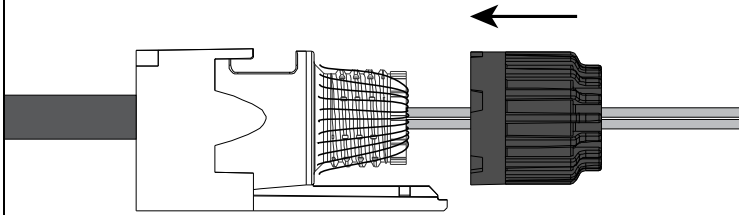

With the aramid yarn between the module threads and twist cap, hand-tighten the twist cap onto the threads of the module using a clockwise motion.

6.

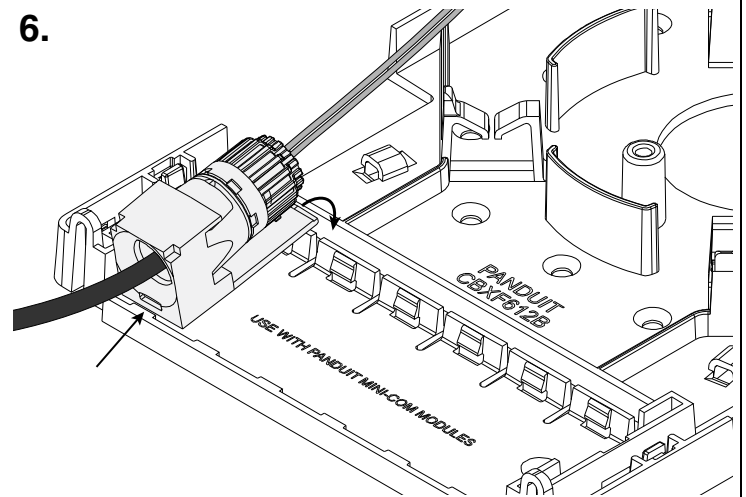

Insert the module(s) into the surface mount box. Align the cutout in the front of the module with the notch on the surface mount box as shown. Push on the rear of the module to snap it into place.

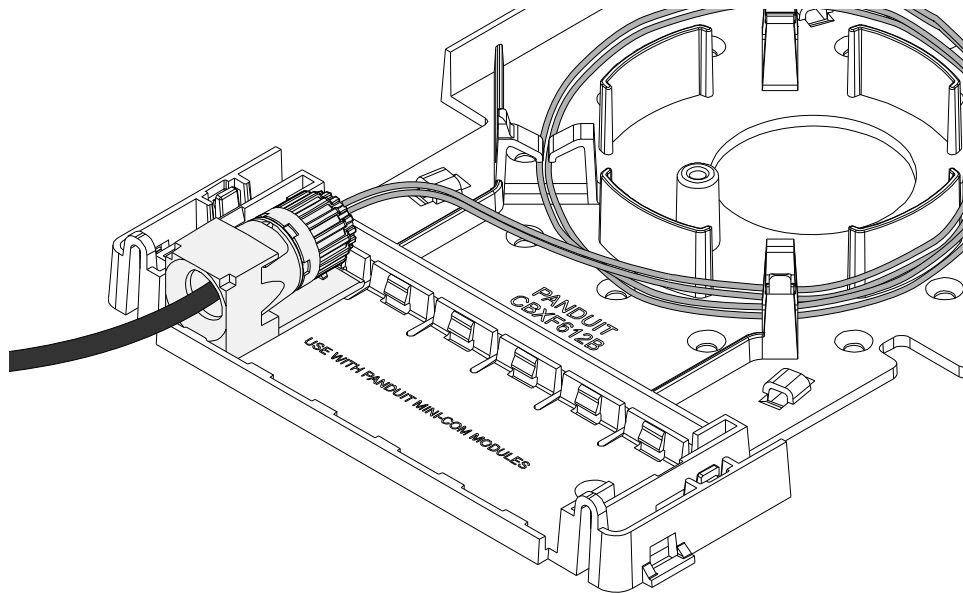

For Instructions in Local Languages
and Technical Support:

www.panduit.com/resources/install_maintain.asp

PANDUIT
www.panduit.com

E-mail:
techsupport@panduit.com

Phone:
866-405-6654