

THIS COPY IS PROVIDED ON A RESTRICTED BASIS AND IS NOT TO BE USED IN ANY WAY DETRIMENTAL TO THE INTERESTS OF PANDUIT CORP.

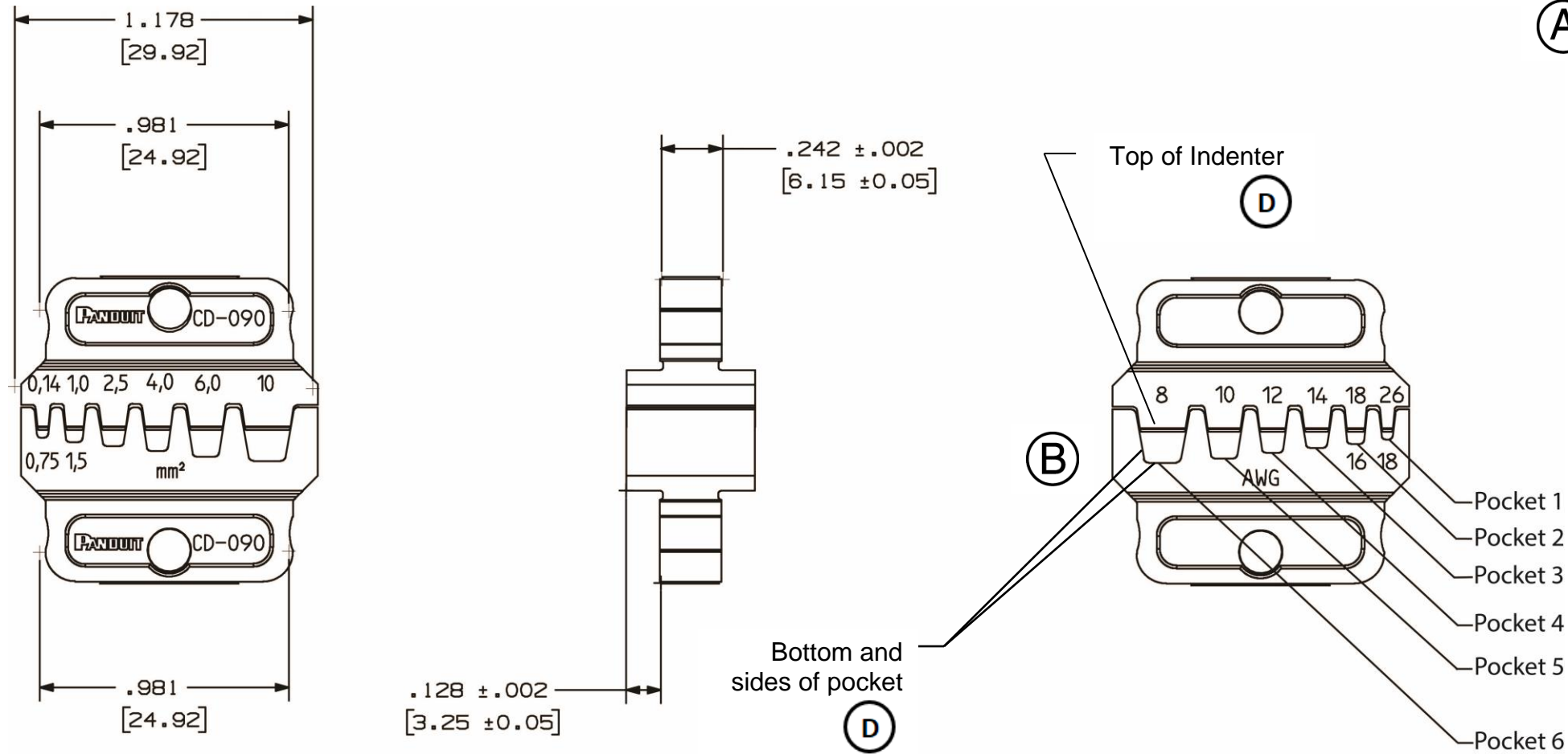

**NOTES, UNLESS OTHERWISE SPECIFIED:**

- Interchangeable Crimp Die Inserts used with CT-2500CH Crimp Head frame and CT-2300 Micro Crimp Tool to crimp Panduit #26 - 8 AWG (0,14 – 10,0mm<sup>2</sup>) insulated and non-insulated single wire ferrules and #22 - 12 AWG (0,05 – 4,0mm<sup>2</sup>) insulated twin ferrules with a square profile
- Laser etched as shown
- Bottom and sides of pockets and top of indenters polished

**(D)**

**WEIGHT:** 4.3 oz. [0.12] kg

DIMENSIONS SHOWN ARE FOR REFERENCE ONLY.

DIMENSIONS IN BRACKETS [MM] ARE METRIC.

CD-090 CRIMP POCKET	ENGLISH GO / NO GO GAGE MEMBERS		METRIC GO / NO GO GAGE MEMBERS	
	"G" Dia. (GO)	"NG" Dia. (NO GO)	"G" Dia. (GO)	"NG" Dia. (NO GO)
1	0.018"	0.026"	0,45mm	0,65mm
2	0.035"	0.043"	0,90mm	1,10mm
3	0.051"	0.059"	1,30mm	1,50mm
4	0.071"	0.079"	1,80mm	2,00mm
5	0.093"	0.104"	2,35mm	2,55mm
6	0.110"	0.118"	2,80mm	3,00mm

CROSS SECTION		
PROFILE	mm <sup>2</sup>	AWG
1	0,14 – 0,75	22 - 18
2	1,0 – 1,5	18 – 16
3	2,5	14
4	4,0	12
5	6,0	10
6	10,0	8

**(C)**

File Location: Teamcenter

							<b>CD-090 DIE SET</b>			
							CUSTOMER DRAWING			
02	5-22-19	BWG	<i>BJPU</i>	<i>JADE</i>	<b>(D)</b> ADDED POLISH AND LASER NOTES AND INDICATED POCKET AND INDENTER.	10220/01	ITEM REVISION NAME: TF28309B01_02			
01	3-15-18	BLR	<i>BJPU</i>	<i>JADE</i>	<b>(A)</b> WAS 26-10(0,14-6,0); <b>(B)</b> ADD	20454	<b>PANDUIT</b>  MATERIAL: _____  DRAWING NUMBER: TF28309B01			
----	----	----	----	----	AWG/SIZE LASER ETCH; <b>(C)</b> ADD	----			UNLESS OTHERWISE SPECIFIED, DIMENSIONAL TOLERANCES ARE: (.x) ± ---      (.xxx) ± --- (.xx) ± ---      ANGLES ± --- THIRD ANGLE PROJECTION	
----	----	----	----	----	AWG COLUMN	----				
00	11-22-16	BLR	<i>BJPU</i>	<i>JADE</i>	RELEASED	11042				