

PANDUIT P/N	WEIGHT
VIM1B3H0A30AHA0	6.3 kg (13.96 lbs)

- NOTES:
- IDENTIFICATION: VERTICAL, MIXED (24) C-13 & (6) C-19, METERED  
230 / 16A / SINGLE-PHASE PDU
  - ACCESSORY COMPONENTS:  
(1) QUICK-START GUIDE
  - PRIMARY DIMENSIONS ARE IN MILLIMETERS, SECONDARY DIMENSIONS IN [INCHES].
  - POWER (e.g. AMPS, VOLTS, kWh, kVA, POWER FACTOR FREQUENCY) MONITORING DATA CAN BE ACCESSED VIA ON-UNIT DISPLAY.
  - RoHS COMPLIANT.
  - VISIT OUR ON-LINE CATALOG AT WWW.PANDUIT.COM FOR A CURRENT LIST OF PRODUCTS APPLICABLE FOR USE WITH THIS PART.
  - MAXIMUM AVAILABLE INPUT POWER = 3.6 kW
  - INSTALLATION SHALL COMPLY WITH ALL APPLICABLE NATIONAL, STATE, AND LOCAL CODES.
  - PRINTED WITH PHASE & CIRCUIT IDENTIFICATION.

PART NO. VIM1B3H0A30AHA0 COLOR BLACK

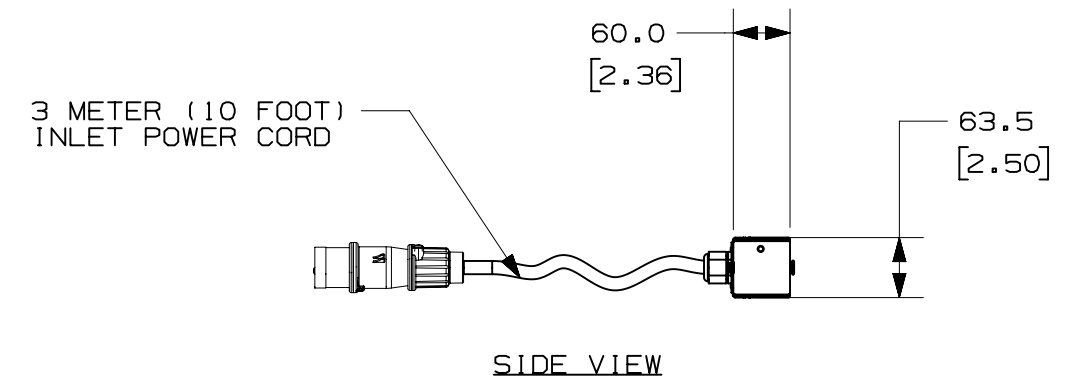

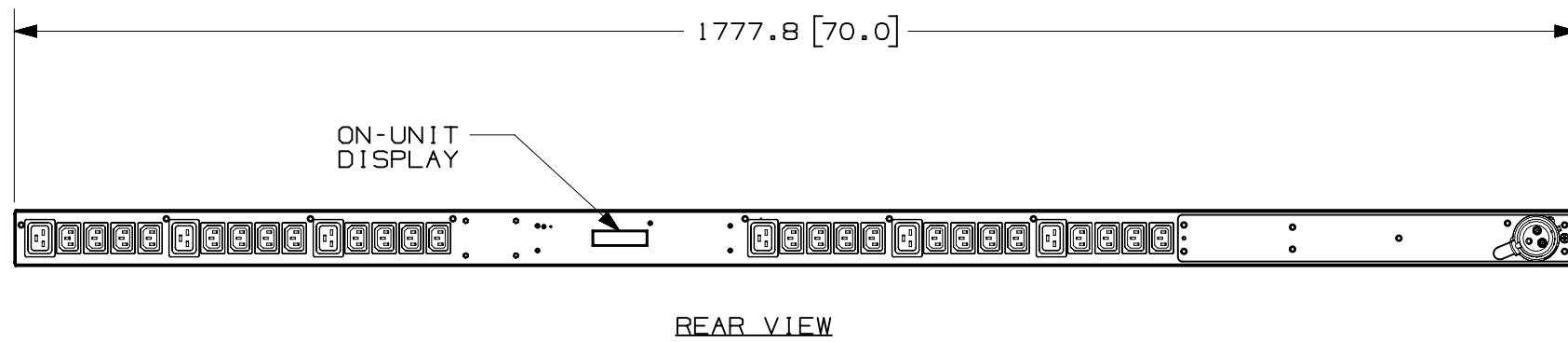
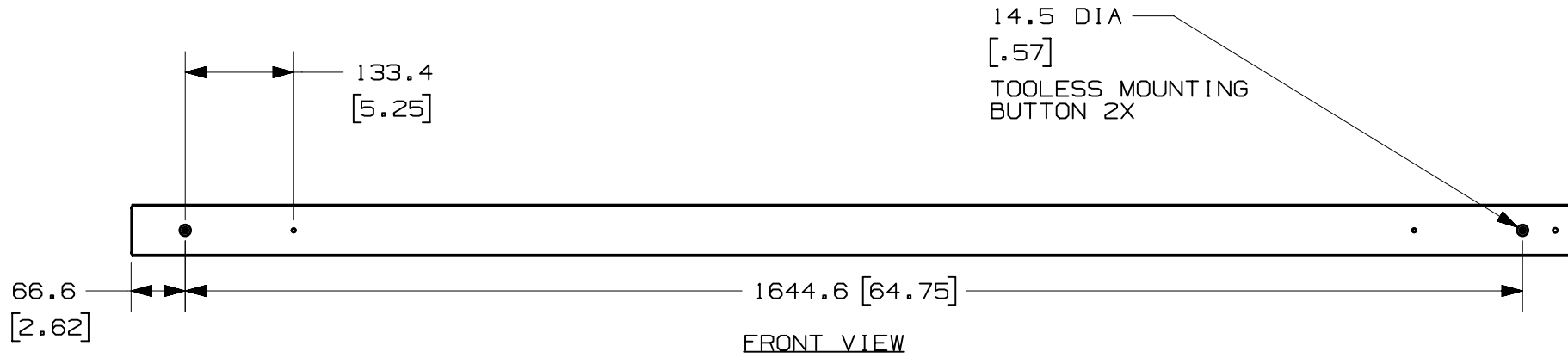
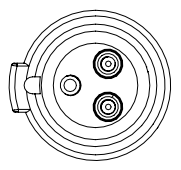

PLUG  
16 AMP, 250V  
2P/3W  
IEC 60309, SPLASHPROOF

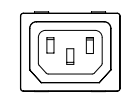

TWENTY-FOUR (24)  
RECEPTACLES  
10 AMP, 250V  
STRAIGHT BLADE  
IEC 60320/C13

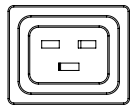

SIX (6)  
RECEPTACLES  
16 AMP, 230V  
STRAIGHT BLADE  
IEC 60320/C19

REV	DATE	BY	CHK	APR	DESCRIPTION	ECN
01A	09/11/14	PJST	MRWA	EDM	RELEASED TO PRODUCTION	12V092BW

WE ASK THAT YOU CHECK FULLY THE DIMENSIONS, NOTES, AND SIGN THE CLIENT SIGNATURE BOX.		SIGN	
THE JOB WILL NOT PROGRESS WITHOUT SIGNED APPROVAL. PLEASE DO NOT DELAY IN RETURNING PROOF AS IT WILL AFFECT DELIVERY.		DATE	
		PRINT	
TITLE <b>BASIC WITH LOCAL METER PDU (24) C13 &amp; (6) C19</b> CUSTOMER DRAWING			
ITEM REVISION NAME 12V092BW/01.PRT			
DATASET FILE NAME 12V092BW_DC/01A.PRT			
UNLESS OTHERWISE SPECIFIED, DIMENSIONAL TOLERANCES ARE:			
INCHES	METRIC - MILLIMETER	ANGLE	
X.X +/- 0.03	X.X +/- 0.8	+/- 1°	
X.XX +/- 0.018	X.X +/- 0.46		
X.XXX +/- 0.007	X.XX +/- 0.18		
DRAWN BY PJST		DATE 09/11/14	CHK MRWA
		SCALE NONE	
		DRAWING NUMBER: <b>12V092BW-DC</b>	
		SHT 1 OF 1	
		SIZE <b>B</b>	